

# VERSA-BELL

## Owner's Manual

Safety Instructions  
Customer Service  
Operation  
Warranty

### SAFETY INSTRUCTIONS

**WARNING:** To reduce the risk of serious injury, read the following Safety Instructions before using the **VERSA-BELL**.

1. Read this Owner's Manual and follow it carefully before using the **VERSA-BELL**.
2. Keep children away from the **VERSA-BELL**. Do not allow children to use or play around the **VERSA-BELL**. Keep children and pets away from the **VERSA-BELL** when it is in use.
3. Make sure the **VERSA-BELL** is resting properly in the Weight Tray.
4. Never adjust the weight selector when the **VERSA-BELL** is not in the weight tray.
5. Inspect the **VERSA-BELL** for damaged or loose components prior to use.
6. Tighten/replace any loose or worn components prior to using the **VERSA-BELL**.
7. Before exercising, make sure both Weight Selectors which secure the Weight Plates are locked in position properly. Falling Weights can result in severe injury.

**CAUTION:** Never adjust the Weight Selector when the **VERSA-BELL** is removed from the Weight Tray.

8. Consult a physician prior to commencing an exercise program. If, at any time during exercise, you feel faint, dizzy, or experience pain, stop and consult your physician.
9. Always choose the workout which best fits your physical strength and flexibility level. Know your limits and train within them. Always use common sense when exercising.
10. Do not wear loose or dangling clothing while using the **VERSA-BELL**.
11. The **VERSA-BELL** is for consumer use only. It is not for use in public or semipublic facilities.

This Product is Produced Exclusively by



2040 N. Alliance, Springfield, MO 65803

Customer Service Number

1 (800) 375-7520

parts@staminaproducts.com

www.staminaproducts.com

When calling for parts or service, please specify the following number:

**05 - 2226B**

MADE IN CHINA

© 2005 Stamina Products, Inc.

# Assembly Instructions

Place all parts from the box in a cleared area and position them on the floor in front of you. Remove all packing materials from your area and place them back into the box. Do not dispose of the packing materials until assembly is completed. Read each step carefully before beginning. If you are missing a part please call our toll-free number for assistance 1 (800) 375-7520 or e-mail us at: [parts@staminaproducts.com](mailto:parts@staminaproducts.com)

THE FOLLOWING TOOLS ARE INCLUDED FOR ASSEMBLY :

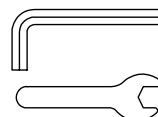

Allen Wrench (4mm)

Wrench

## STEP 1

Attach the **FRONT** and **REAR PLATFORMS** (26, 22) onto both **MAIN FRAMES**(21) with **BOLTS**(1/4" x 1 3/16")(27), **NYLOCK NUTS** (1/4")(28), and **WASHERS**(1/4")(29).

**NOTE: DO NOT TIGHTEN BOLTS UNTIL ALL PARTS ARE IN CORRECT POSITION.**

## STEP 2

Attach the **CONNECTION BAR**(23) onto both **MAIN FRAMES**(21) with **BOLTS**(1/4" x 1 3/16")(27), **NYLOCK NUTS**(1/4")(28), and **WASHERS**(1/4")(29). Tighten all of the **BOLTS**.

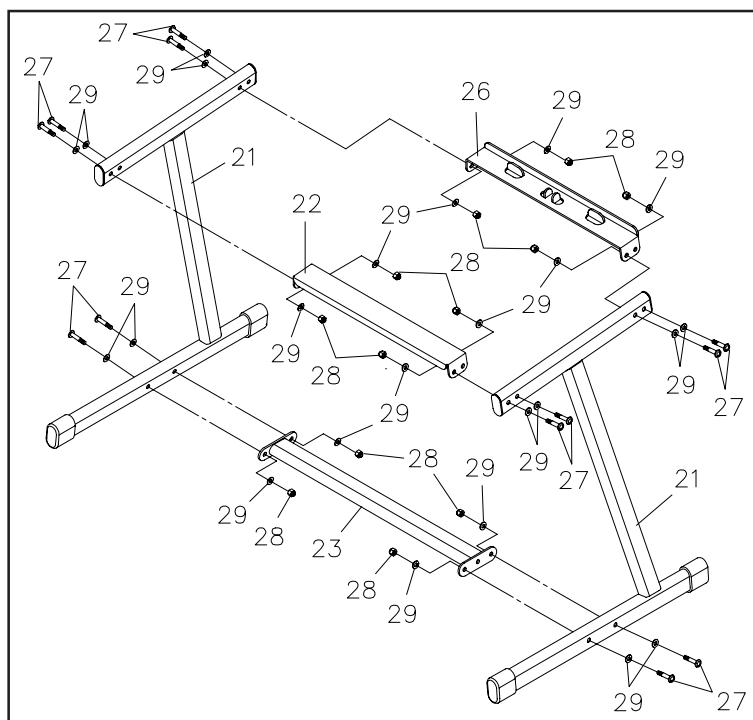

## STEP 3

Place the two **WEIGHT TRAYS**(1) onto the **FRONT** and **REAR PLATFORMS**(26, 22). The **WEIGHT TRAYS**(1) must cover over the Protruding Brackets on the **FRONT PLATFORM**(26).

## STEP 4

Insert the **WEIGHT CAGES**(20) all the way into the holes in the **WEIGHT TRAYS**(1). Properly place the **VERSA-BELL SETS** into the **WEIGHT TRAYS**(1).

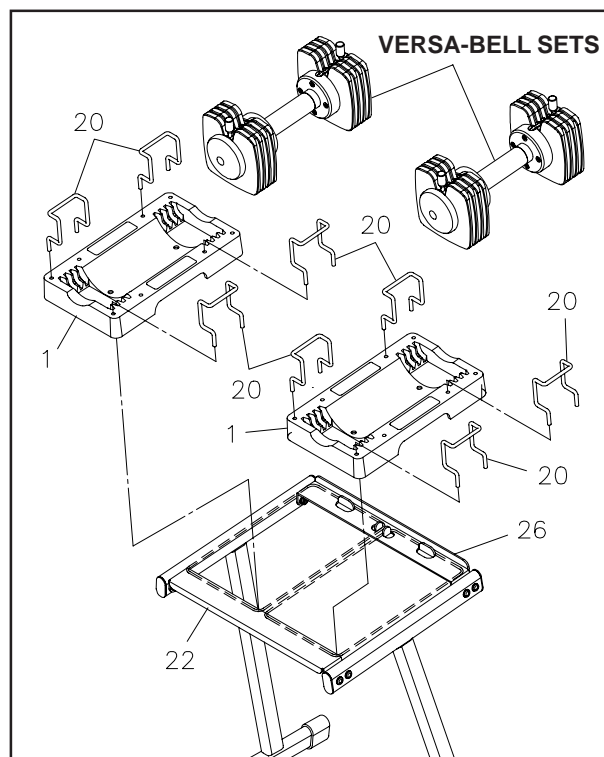

# Operational Instructions

**VERSA-BELL** has an internal slider system that allows the user to adjust the weights on both sides of the bar. Follow the process below to adjust and workout with your **VERSA-BELL** :

1. While in the Weight Tray, pull up on the **WEIGHT SELECTOR(11)** to release. Move left or right depending upon desired weight. Repeat on the other side.
2. Lift the **VERSA-BELL** approximately 6 inches from the Weight Tray and check the **WEIGHT PLATES(2)**.  
**CAUTION: Never adjust the WEIGHT SELECTOR(11) when the VERSA-BELL is removed from the Weight Tray.**
3. Begin workout when the Weight Plates are secure.

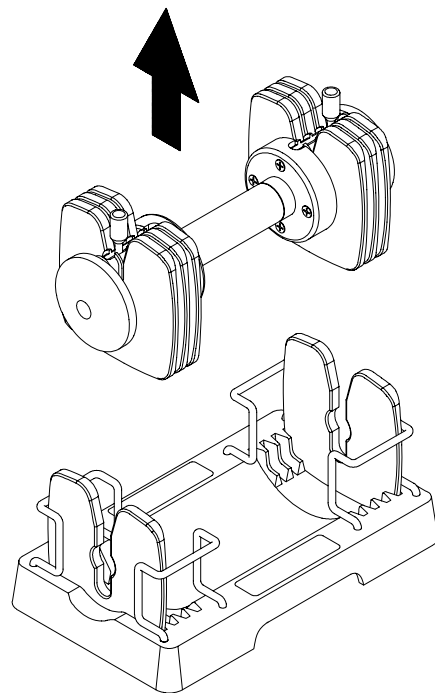
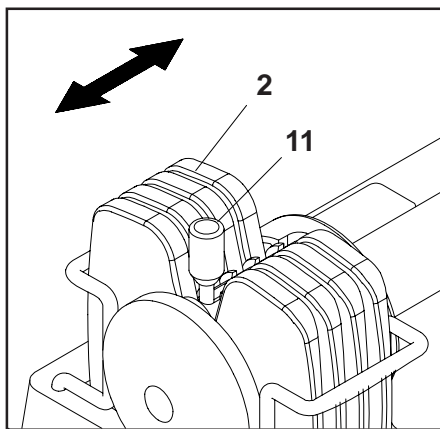

We recommend that you keep the **VERSA-BELL** balanced as closely as possible. For example, if three weights are used, use two on one side and one on the other side. The illustrations below show the proper setup for 5, 10, 15, 20, and 25 pounds.

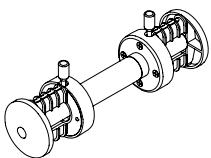

**5 LBS**  
No Plate

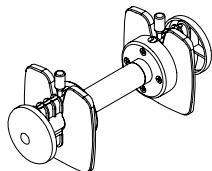

**10 LBS**  
One Plate  
on Each Side

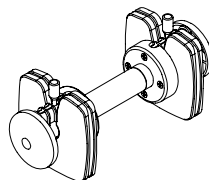

**15 LBS**  
Two Plates  
on Each Side

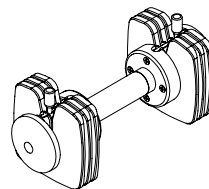

**20 LBS**  
Three Plates  
on Each Side

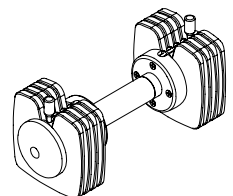

**25 LBS**  
Four Plates  
on Each Side

# Product Parts Drawing and Parts List

## VERSA-BELL SET

This product includes two sets of dumbbells (VERSA-BELLS). The following illustration shows the parts detail of a VERSA-BELL set.

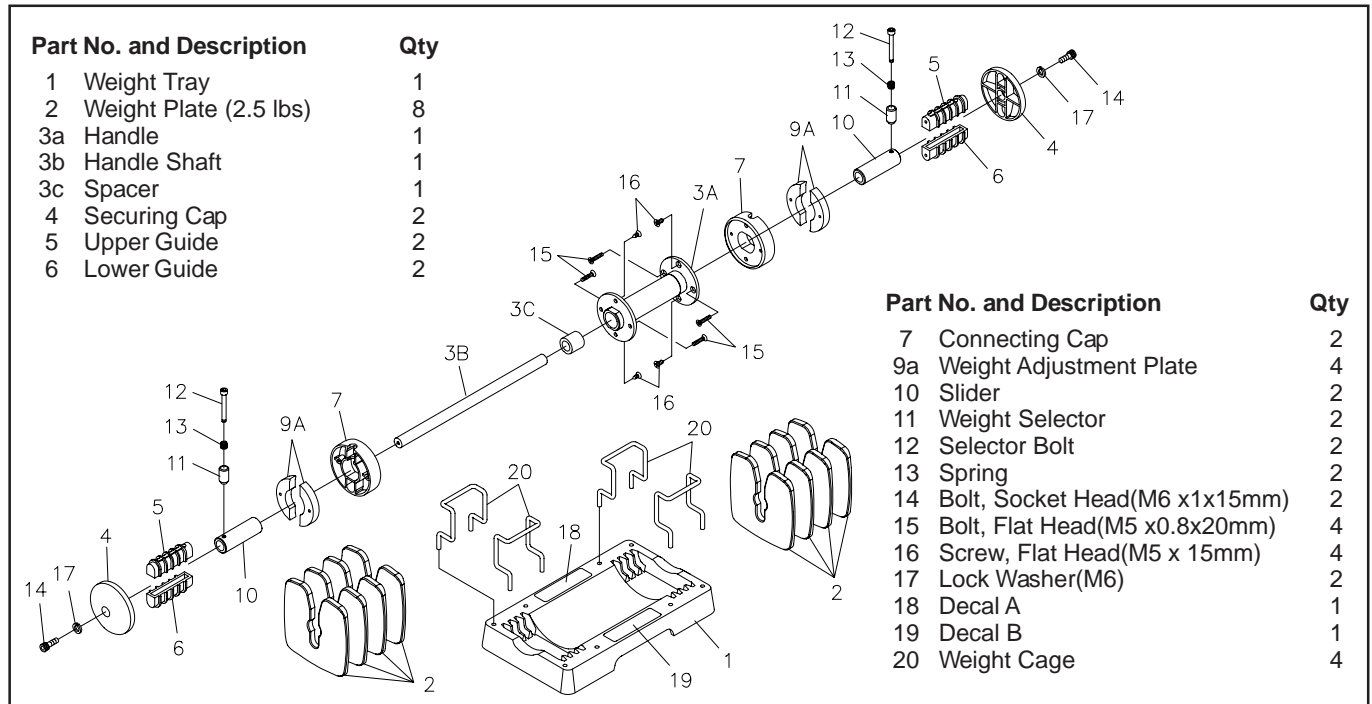

## VERSA-BELL RACK

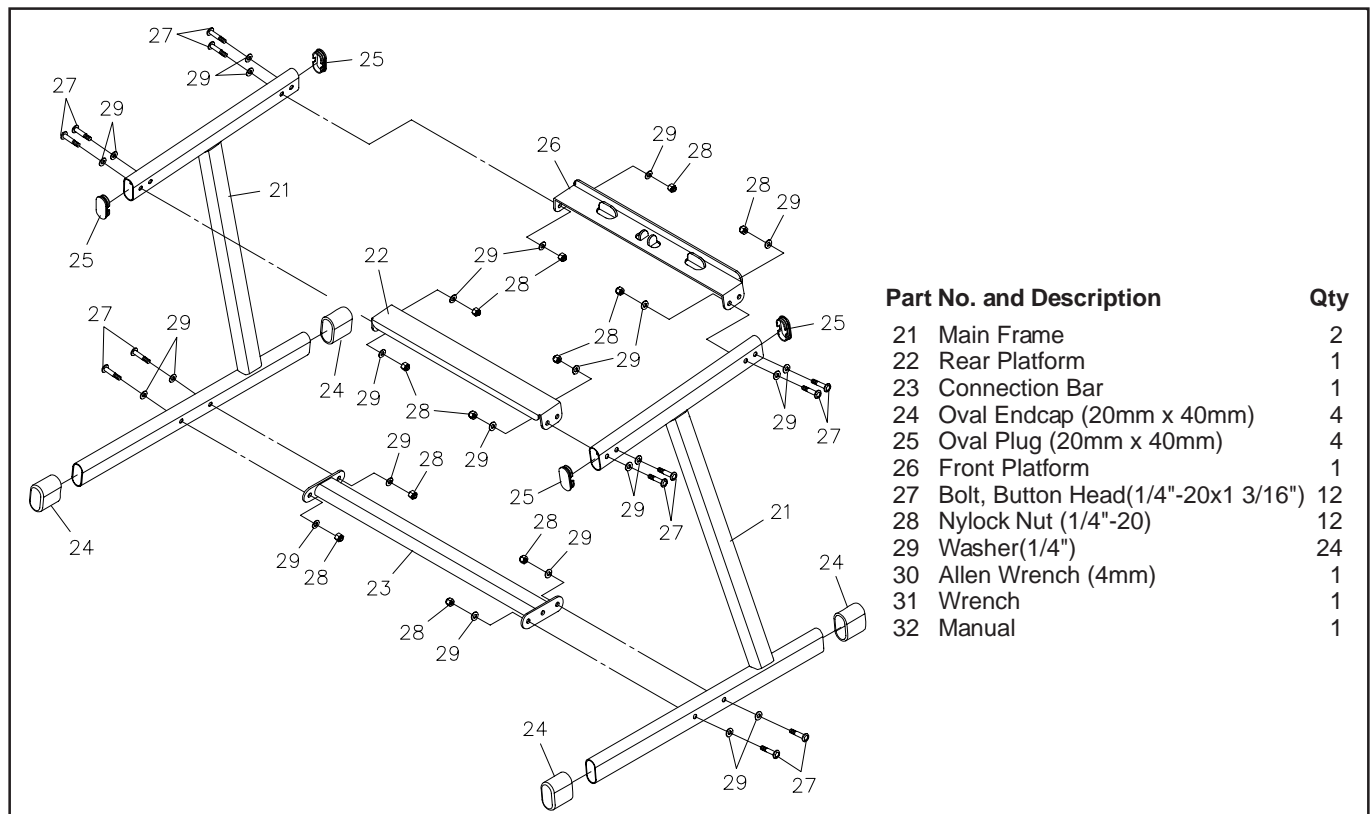

# LIMITED WARRANTY

MODEL 05-2226B

## WARRANTY

Stamina Products, Inc. warrants that this product will be free from defects in materials and workmanship under normal use, service and proper operation for a period of 90 days on the parts and the frame from the date of the original purchase from an authorized retailer. **THIS WARRANTY SHALL NOT APPLY TO ANY PRODUCT WHICH HAS BEEN SUBJECT TO COMMERCIAL USE, ABUSE, MISUSE, ALTERATION OF ANY TYPE OR CAUSE OR TO ANY DEFECT OR DAMAGE CAUSED BY REPAIR, REPLACEMENT, SUBSTITUTION OR USE WITH PARTS OTHER THAN PARTS PROVIDED BY STAMINA PRODUCTS, INC.** Commercial use includes use of the product in athletic clubs, health clubs, spas, gymnasiums, exercise facilities, and other public or semipublic facilities whether or not the product's use is in furtherance of a profit making enterprise, and all other use which is not for personal, family, or household purposes.

To implement this limited warranty, send a written notice stating your name, date, and place of purchase and a brief description of the defect along with your receipt to **Stamina Products, Inc. P.O. Box 1071, Springfield Missouri, USA, 65801-1071** or call us at **1 (800) 375-7520**. If the defect is covered under this limited warranty, you will be requested to return the product or part to us for free repair or replacement at our option. **NO ACTION FOR BREACH OF THIS LIMITED WARRANTY MAY BE COMMENCED MORE THAN ONE (1) YEAR AFTER THE DATE THE ALLEGED BREACH WAS OR SHOULD HAVE BEEN DISCOVERED. NO ACTION FOR BREACH OF ANY IMPLIED WARRANTY MAY BE COMMENCED MORE THAN ONE (1) YEAR AFTER DELIVERY OF THE PRODUCT TO THE PURCHASER.** This limited warranty is not transferable. **IF ANY PART OF THE PRODUCT IS NOT IN COMPLIANCE WITH THIS LIMITED WARRANTY OR ANY IMPLIED WARRANTY, THE REMEDY OF REPAIR OR REPLACEMENT IS THE EXCLUSIVE REMEDY AVAILABLE TO YOU.** In the event that the purchaser makes any claim under this limited warranty or any implied warranty, the Warrantor reserves the right to require the product to be returned for inspection, at the purchaser's expense, to the Warrantor's premises in Springfield, Missouri. Return of the enclosed warranty registration card is not required for warranty coverage, but is merely a way of establishing the date and place of purchase.

Stamina Products, Inc. **SHALL NOT BE LIABLE FOR THE LOSS OF USE OF ANY PRODUCT, LOSS OF TIME, INCONVENIENCE, COMMERCIAL LOSS OR ANY OTHER INDIRECT, CONSEQUENTIAL, SPECIAL OR INCIDENTAL DAMAGES DUE TO BREACH OF THE ABOVE WARRANTY OR ANY IMPLIED WARRANTY.**

This limited warranty is the only written or express warranty given by Stamina Products, Inc. This warranty gives you specific legal rights, and you may also have other legal rights which vary from state to state. **ANY OTHER RIGHT WHICH YOU MAY HAVE, INCLUDING ANY IMPLIED WARRANTY OR MERCHANTABILITY OR FITNESS FOR A PARTICULAR PURPOSE, IS LIMITED IN DURATION TO THE DURATION OF THIS WARRANTY.**

The laws in some jurisdictions restrict the rights of manufacturers and distributors of consumer goods to disclaim or limit implied warranties and consequential and incidental damages with respect thereto. If any such law is found to be applicable, the foregoing disclaimers and limitations of and on implied warranties and consequential and incidental damages with respect thereto shall be disregarded and shall be deemed not to have been made to the extent necessary to comply with such legal restriction.

# NOTES